

# Evo White

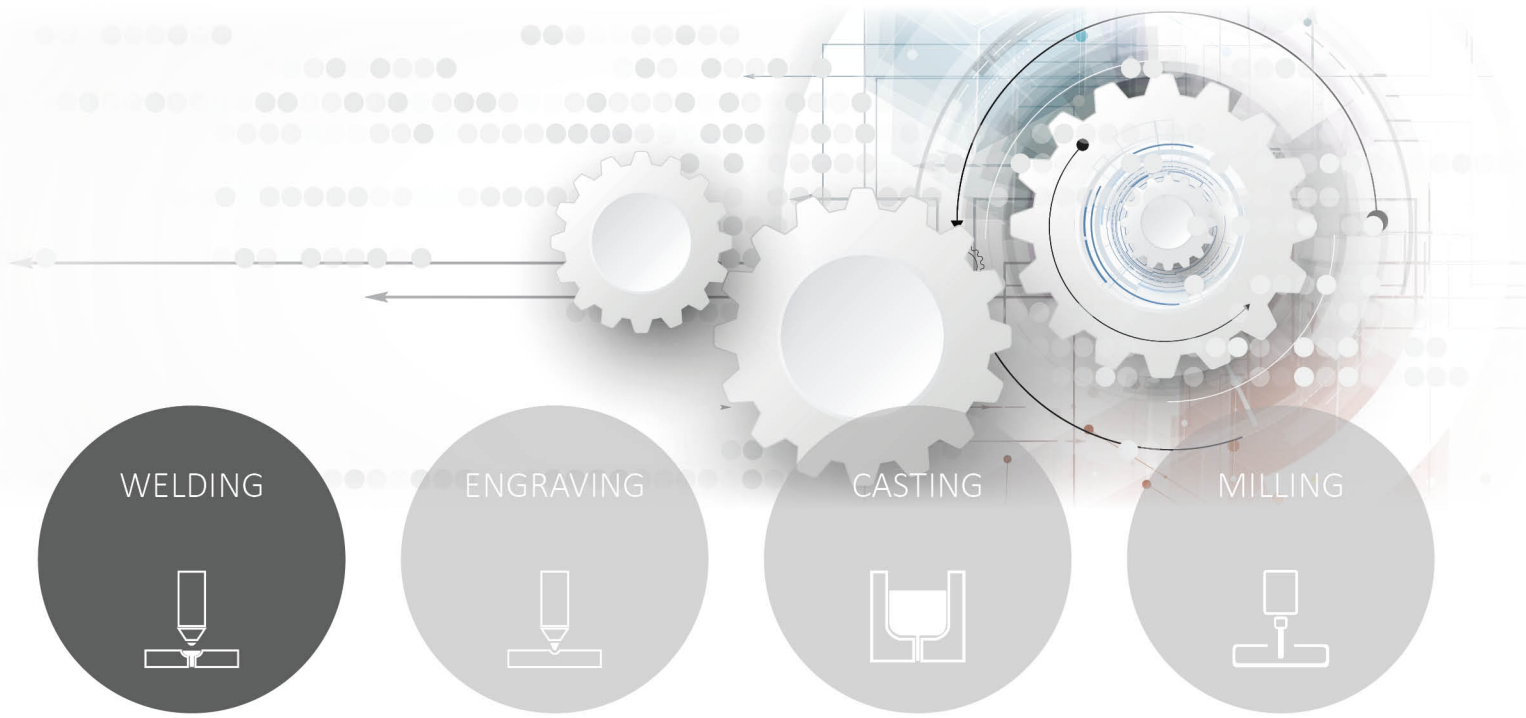

**OROTIG**

The EVO series LASER welder is the world's most recognizable LASER for the jewellery and dental industries, it's main well known features are:

Stereo microscope Leica 10x

Mechanic and electronic safety shutters to guarantee maximum protection

Led lighting system with dimmer

Argon, Nitrogen, Air supply coaxial or they can be supplied through a nozzle in the welding chamber

User interface with touch-screen display

USB pen drive for firmware updates and real-time diagnostics

Wide welding chamber

Parameters can be set using a joystick inside the welding chamber



### TECHNICAL DATA

MODEL	EVO WHITE	EVO WHITE LYNX
CRYSTAL TYPE Nd:YAG	7 mm / 1064 nm	7 mm / 1064 nm
POWER IMPULSE AND TIME	160 J at 25 ms	160 J at 25 ms
PEAK POWER	7 kW	7 kW
MEAN POWER	75 W	75 W
STEREO - MICROSCOPE	45° with 10X and crosshair (Leica)	LYNX
FEQUENCY	15 Hz	15 Hz
WEIGHT	32 Kg	34 Kg

### OTHER

POWER SUPPLY	115-230 VAC±10%, 50/60Hz, 16 A
LASER SPOT DIMENSION	From 0.3 to 1.5 mm
CONTROLS	External with 3.5" color touch-screen display. Internal with joystick
COOLING TYPE	Liquid cooled (1 lt) with forced ventilation

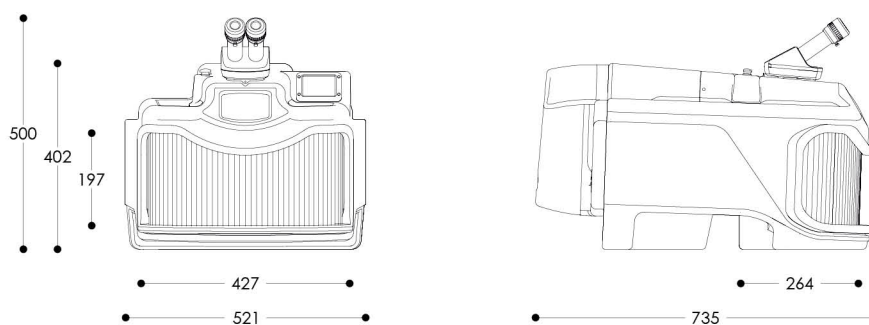

### OPTIONALS



UVC SYSTEM



LYNX



TABLE

FOLLOW US NOW



Via XXV Aprile 47 37014 Cavalcaselle di Castelnuovo del Garda (VR)  
 TEL 045 640 0865 - FAX 045 640 1104  
 www.orotig.com - e-mail: info@orotig.com

ADP00298-01